

ALBED

M I L A N O 1 9 6 4

TECHNICAL BOOK
Walk-in wardrobe
SOLO

TECHNICAL BOOK SOLO - RELEASE 2.0 DATED 22/12/2015

PRODUCT'S CARD N° SL1

Product and legal denomination: WALK-IN WARDROBE

Commercial name: SOLO

Typology: ALUMINIUM AND GLASS OR WOOD

PRODUCTS' COMPONENTS	USED MATERIALS
METAL PARTS	Upright, bracket and clothes hanger in profiled aluminium UNI 3569. Finishing: brushed anodized UNI 10681.
GLASS PARTS	Tempered glass mm.4 \ 6 UNI EN 12150-1:2001 or stratified 3+3 UNI EN 572-1 UNI EN 572-2 UNI EN 12543. Finishing: float light or acid-etched or lacquered.
SHELVES/ CONTAINERS	Structure made up of panels derived from wood.
GASKETS AND OTHER ACCESSORIES	Parry profile in plastic. Hinge: steel or zama.
POSSIBLE HARMFUL SUBSTANCES TO HEALTH	None.
ORDINARY MAINTENANCE	Clean with a soft cloth, slightly dampened and free from products containing solvent and/or abrsive material.
WARNINGS	The assembly must be made only by expert people.

These cards of certification of the product comply with all what the law n.206 del 06.09.2005 prescribes.

DELMONTE S.R.L IS CERTIFIED WITH THE MANAGEMENT SYSTEM FOR THE QUALITY ACCORDING TO UNI EN ISO 9001:2000, FOR THE ACTIVITY OF PLANNING AND PRODUCTION OF DOORS FOR INTERIORS, FURNISHINGS AND COMPLEMENTS FURNITURE IN ALUMINIUM.



FINISHINGS

SUPPORT FOR SHELF AND UPRIGHTS



COMPONENTS, DOORS, SIDES AND BACKS

Lacquered:

RAL lacquered



Melaminic :

White

Louvre

Carbone



Wood :

Horizontal grain for back

Vertical grain for back

Wengé

Noce Canaletto

Frassino light brown

Frassino lounge brown

Frassino Carbone

Frassino Smoky Grey



DOORS, SIDES AND BACKS IN GLASS

Neutro

Acidato

Bianco latte

Neutro extrachiaro

Specchio

Fumé

Bronzo



CAT.A



CAT.A

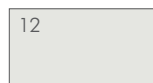

CAT.A



CAT.B

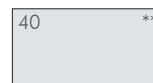

CAT.B

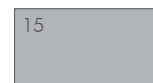

CAT.B



CAT.B

Acidato extrachiaro

Fumé acidato

Bronzo acidato

Smoked reflex

Bronze reflex

Specchio acidato

Specchio bronzo



CAT.C

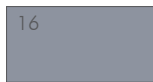

CAT.C

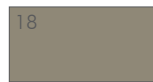

CAT.C

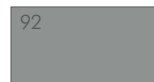

CAT.C

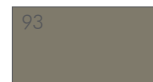

CAT.C



CAT.C



CAT.C

Blu notte

Tortota

Sughero

Ardesia

Nero

Neve acidato

Bianco neve extrachiaro



CAT.C



CAT.C



CAT.C



CAT.C



CAT.C



CAT.D



CAT.D

Canapa

Senape

Rosso fuoco

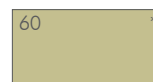

CAT.D

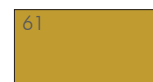

CAT.D

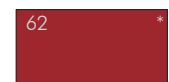

CAT.D

*Glasses are lacquered on just one side so the external side will be glossy and the internal one will be painted

** Backs have mirror just on the outside (glass with safety film).

WALK-IN WARDROBE SOLO

VERTICAL SECTION OF A WALL SOLUTION

Shelves and equipment can be freely arranged.

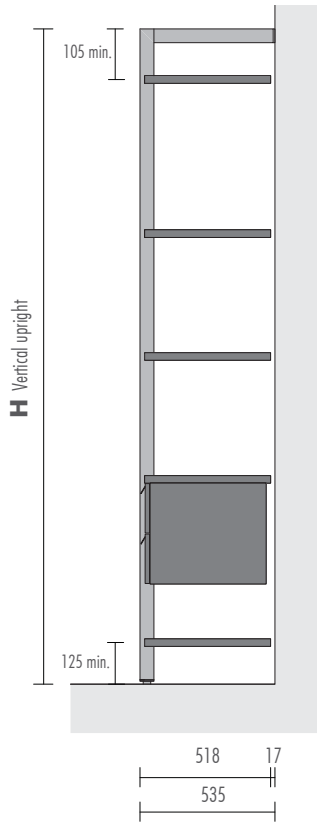

COMPONENTS' LIST FOR WALL UPRIGHT SOLUTION

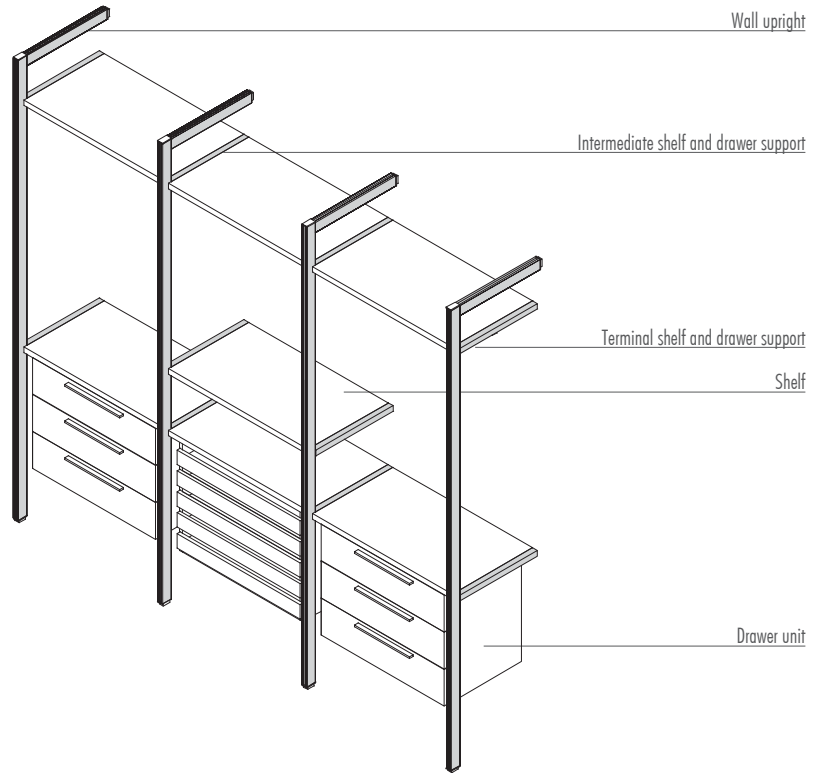

VERTICAL SECTION OF A CEILING SOLUTION

Shelves and equipment can be freely arranged.

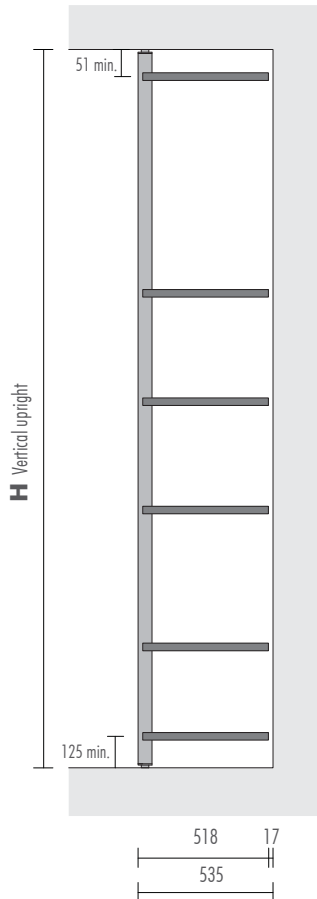

COMPONENTS' LIST FOR CEILING SOLUTION

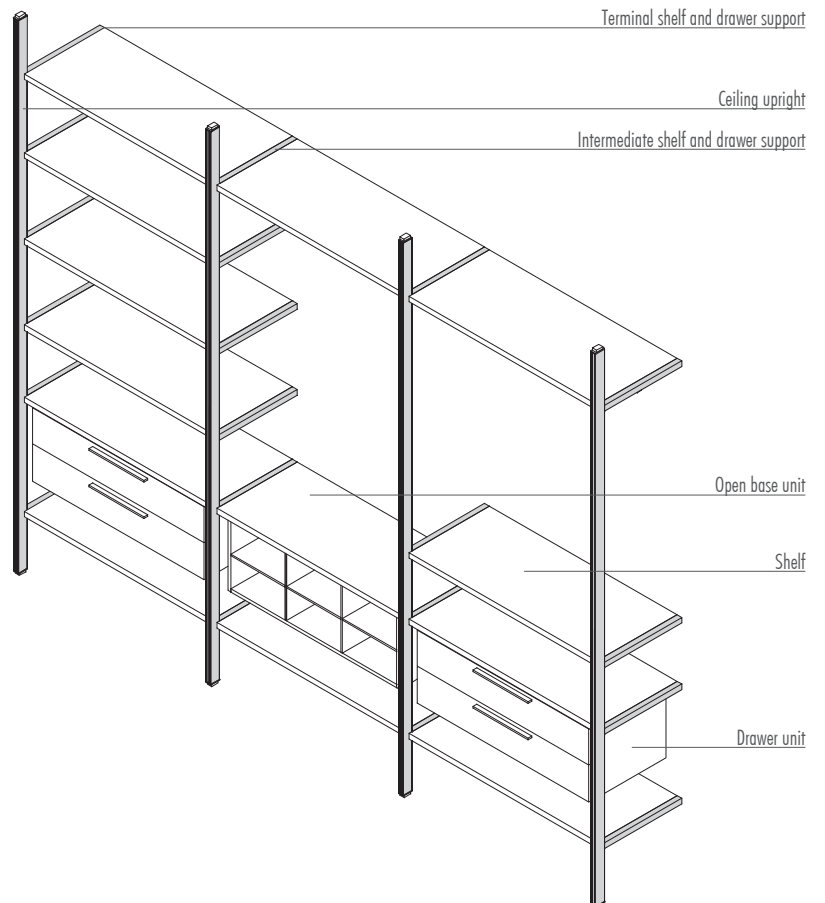

WALL FIXING SOLUTION

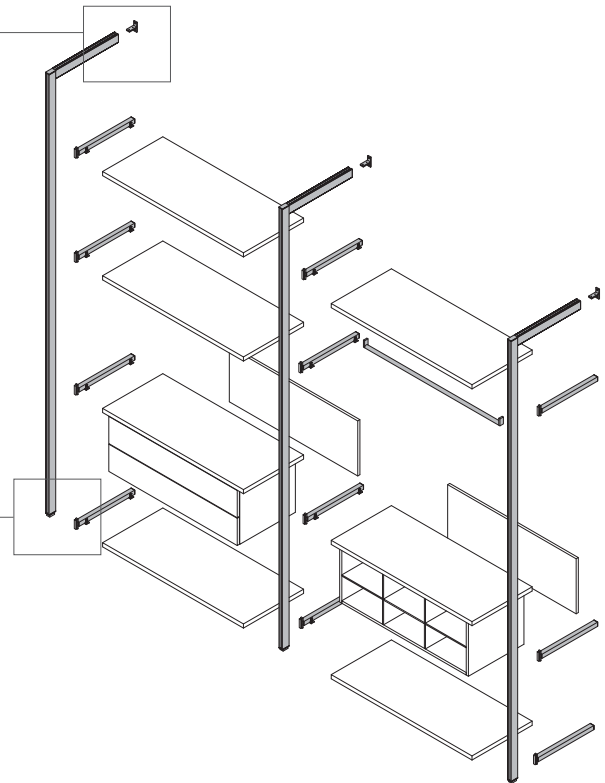
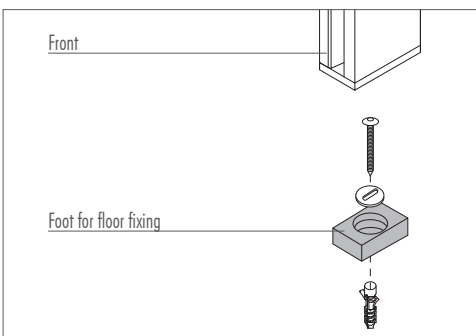
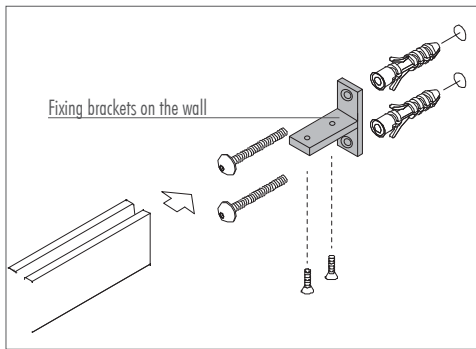

CEILING FIXING SOLUTION

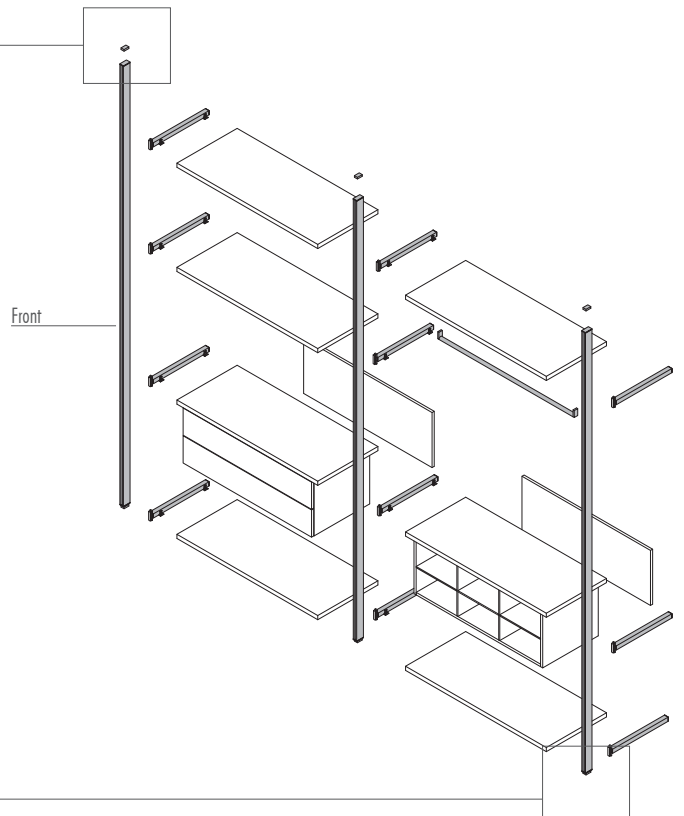
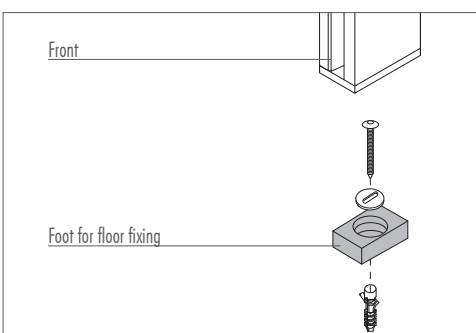
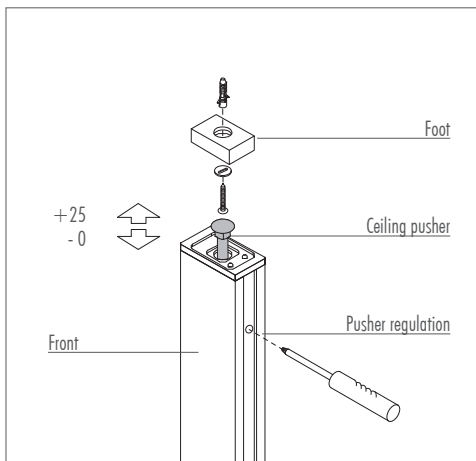

WALK-IN WARDROBE SOLO

MODULE DIMENSIONS FOR WALL FIXING STRUCTURE

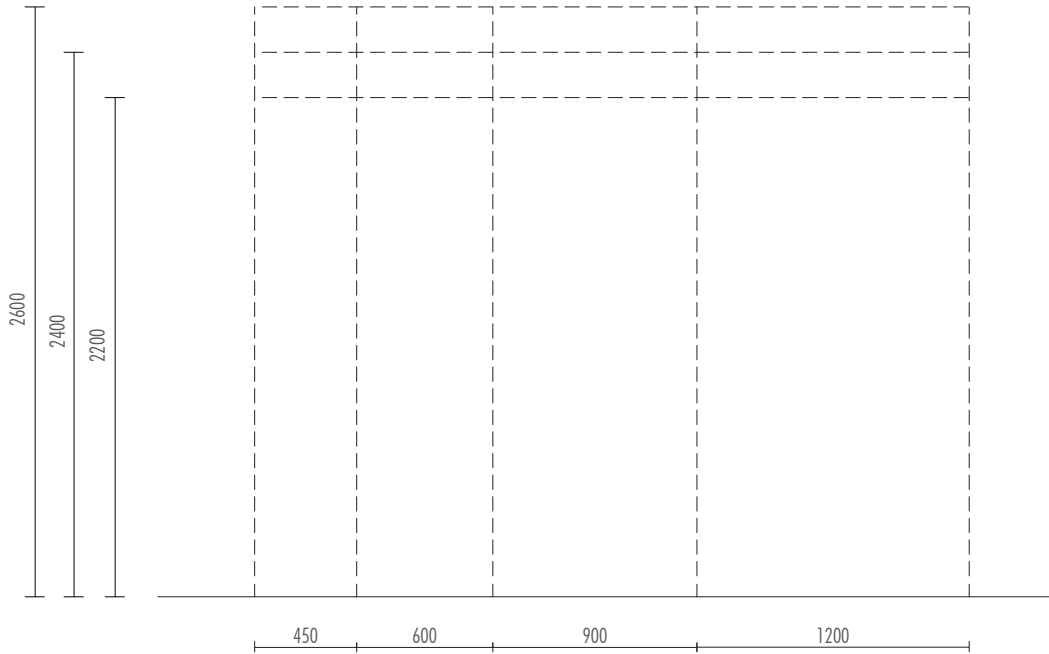

MODULE DIMENSIONS FOR CEILING FIXING STRUCTURE

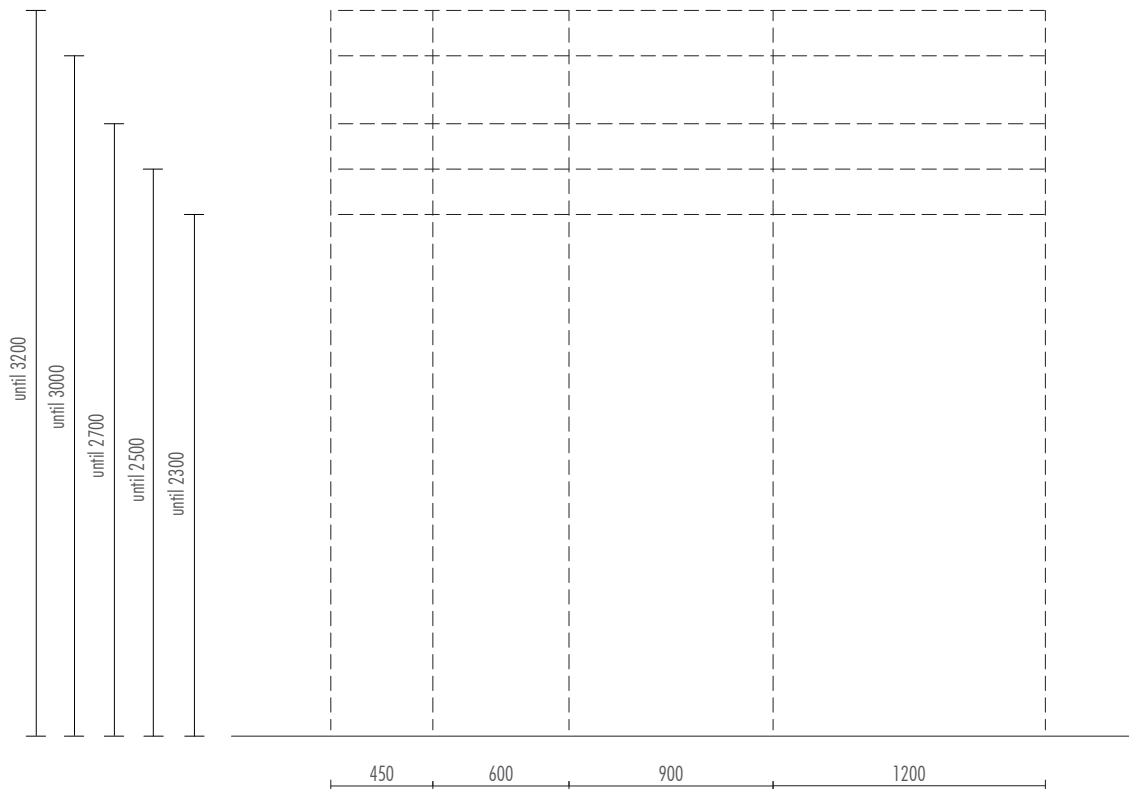

DETAIL 1

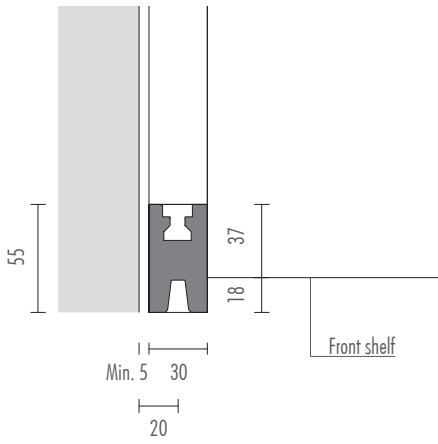

DETAIL 2

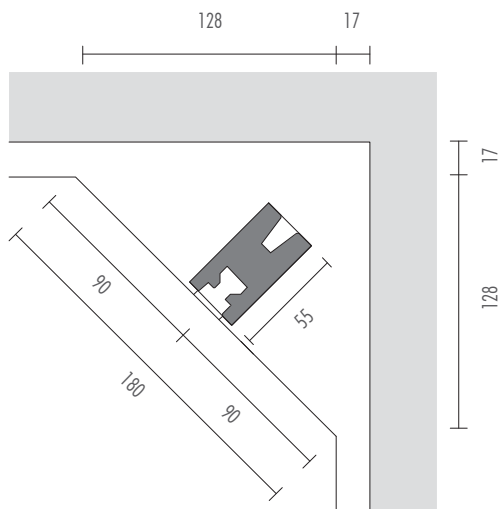

RECTILINEAR SOLUTION

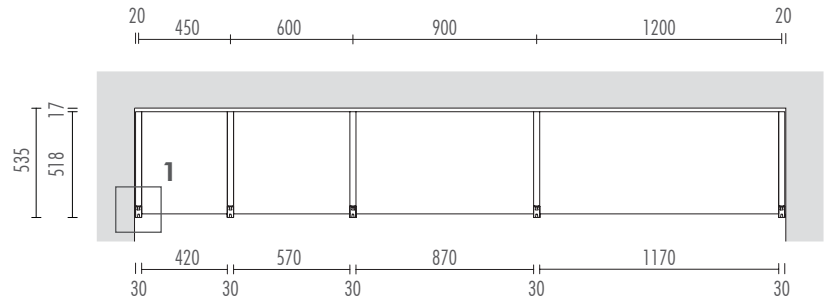

CORNER SOLUTION

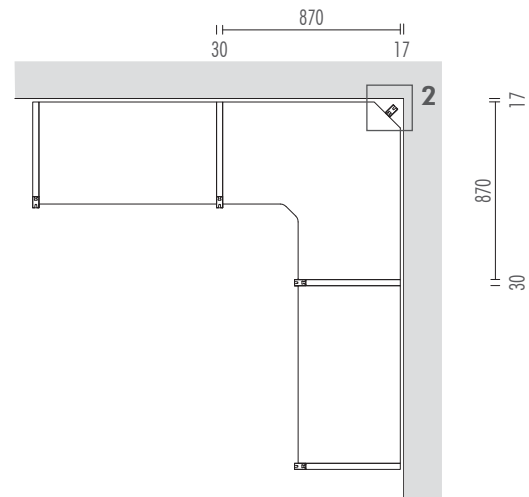

CUSTOM MADE SOLUTION

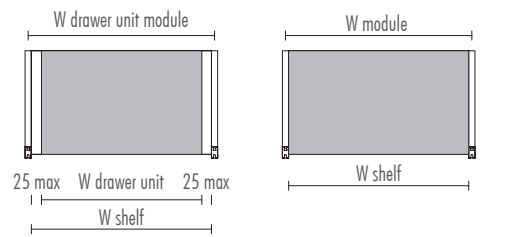

Customised drawer modul width = drawer unit module width - 50 mm MAX

WALK-IN WARDROBE SOLO IN NICHE

VERTICAL SECTION OF NICHE SOLUTION with glass doors

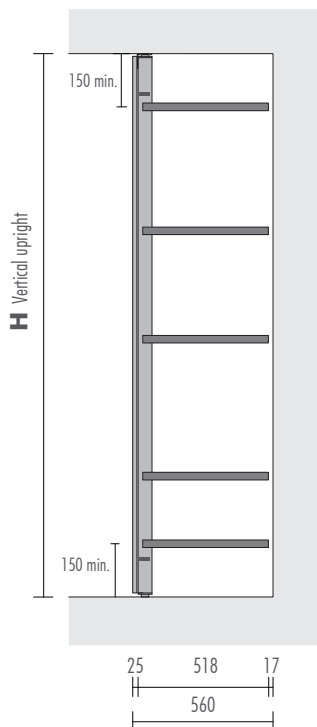

Shelves and equipment can be freely arranged.

VERTICAL SECTION OF NICHE SOLUTION with wooden doors

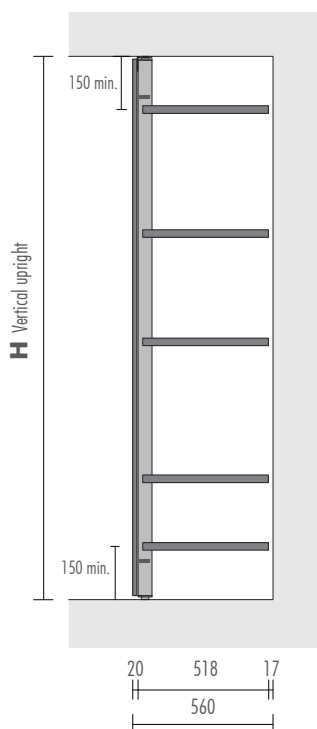

Shelves and equipment can be freely arranged.

COMPONENTS' LIST OF NICHE SOLUTION

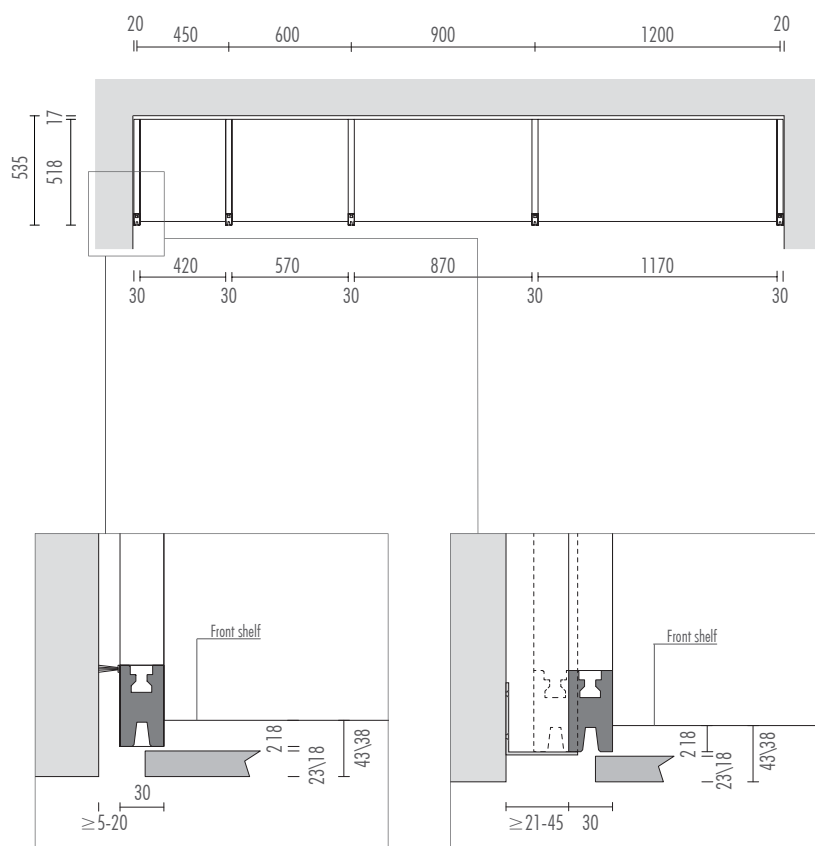
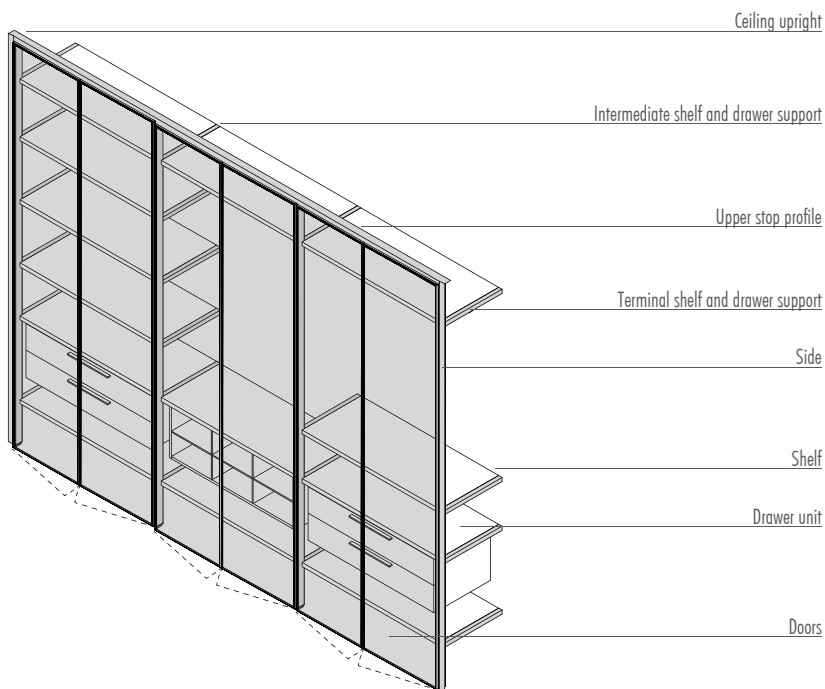

NICHE SOLUTION FIXING

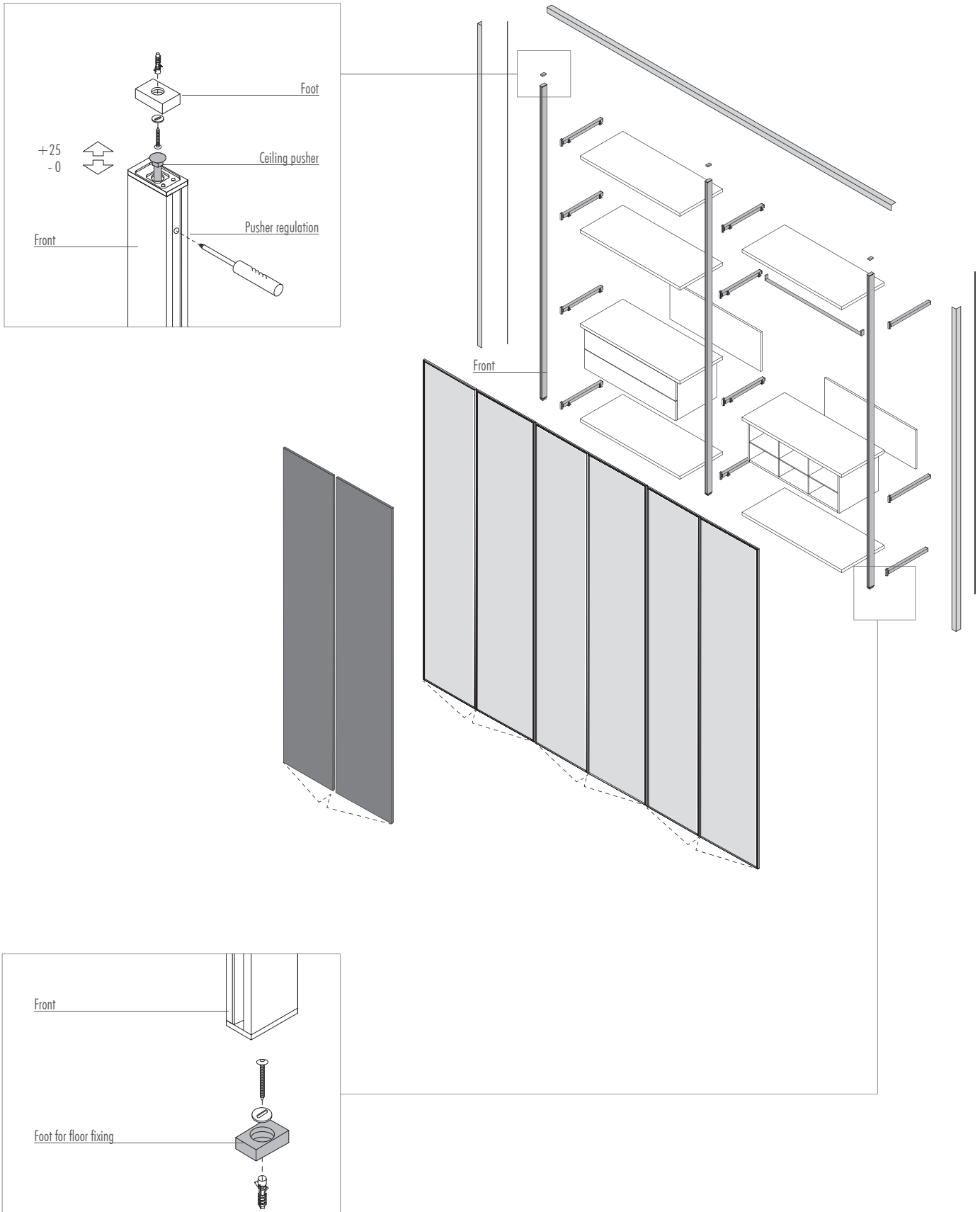

EQUIPMENT

SHELF

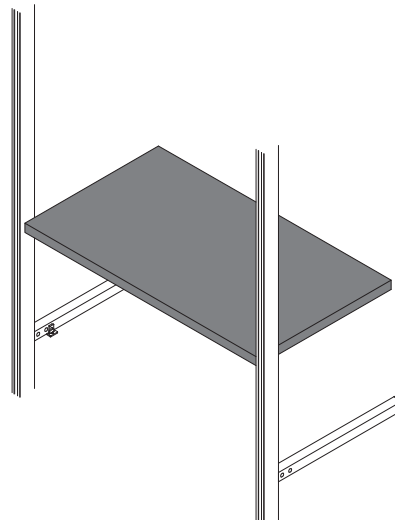

W STANDARD = 420 / 570 / 870 / 1170

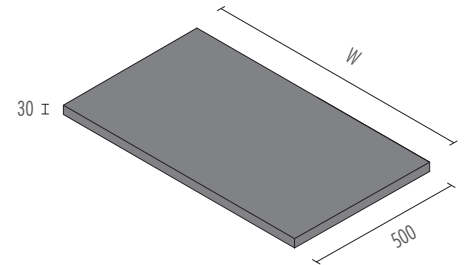

SHELF WITH CLOTHES HANGER

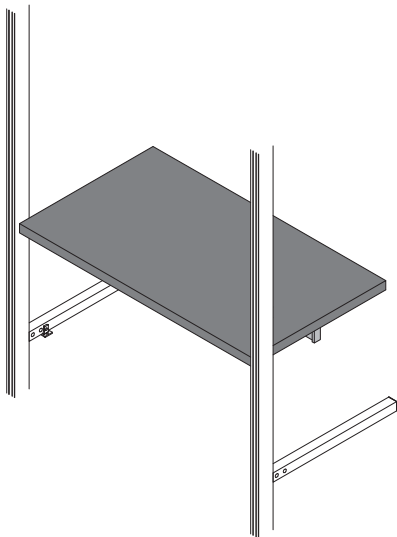

W STANDARD = 420 / 570 / 870 / 1170

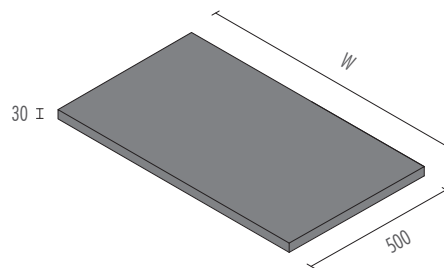

W1 = W standard - 60 mm

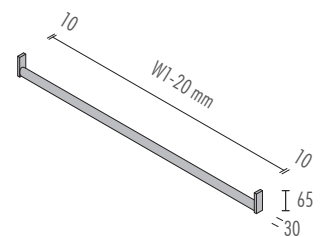
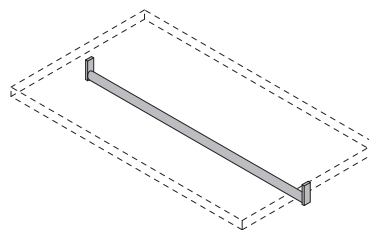
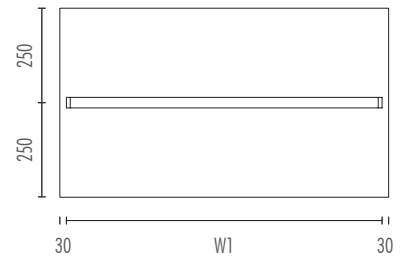

SHELF FOR SHOES

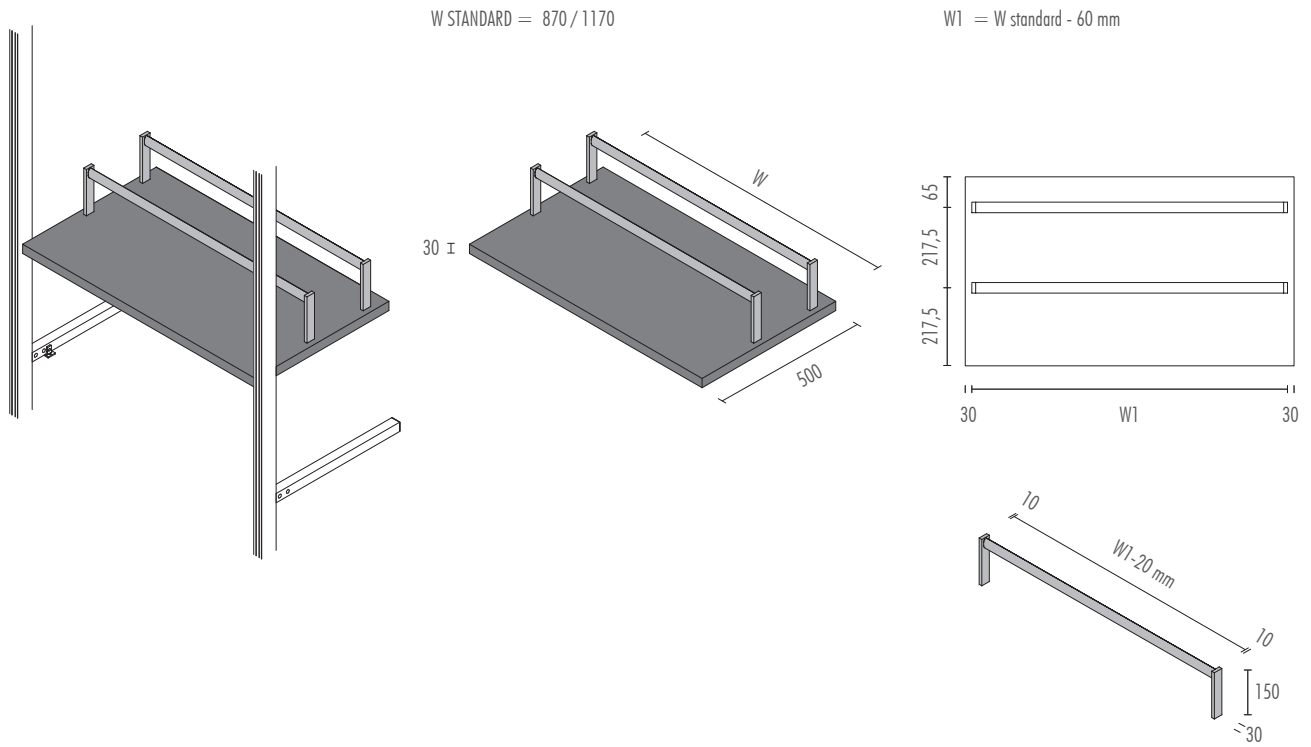

TROUSERS HANGER

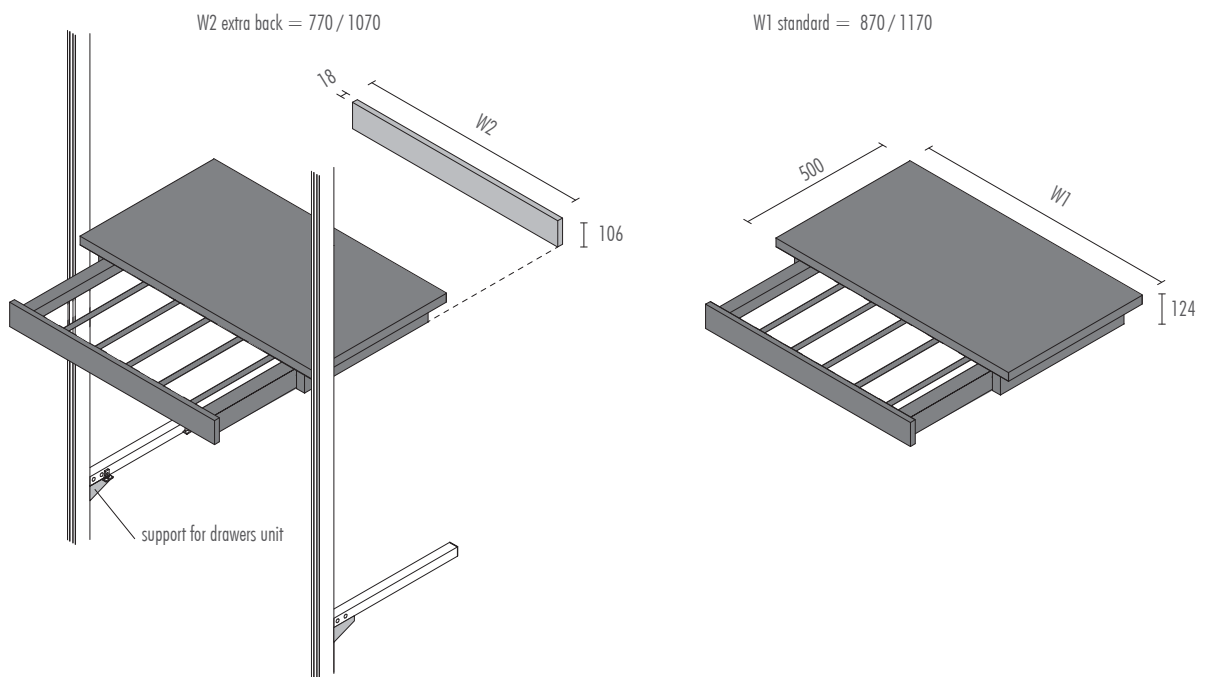

EQUIPMENT

1 DRAWER UNIT

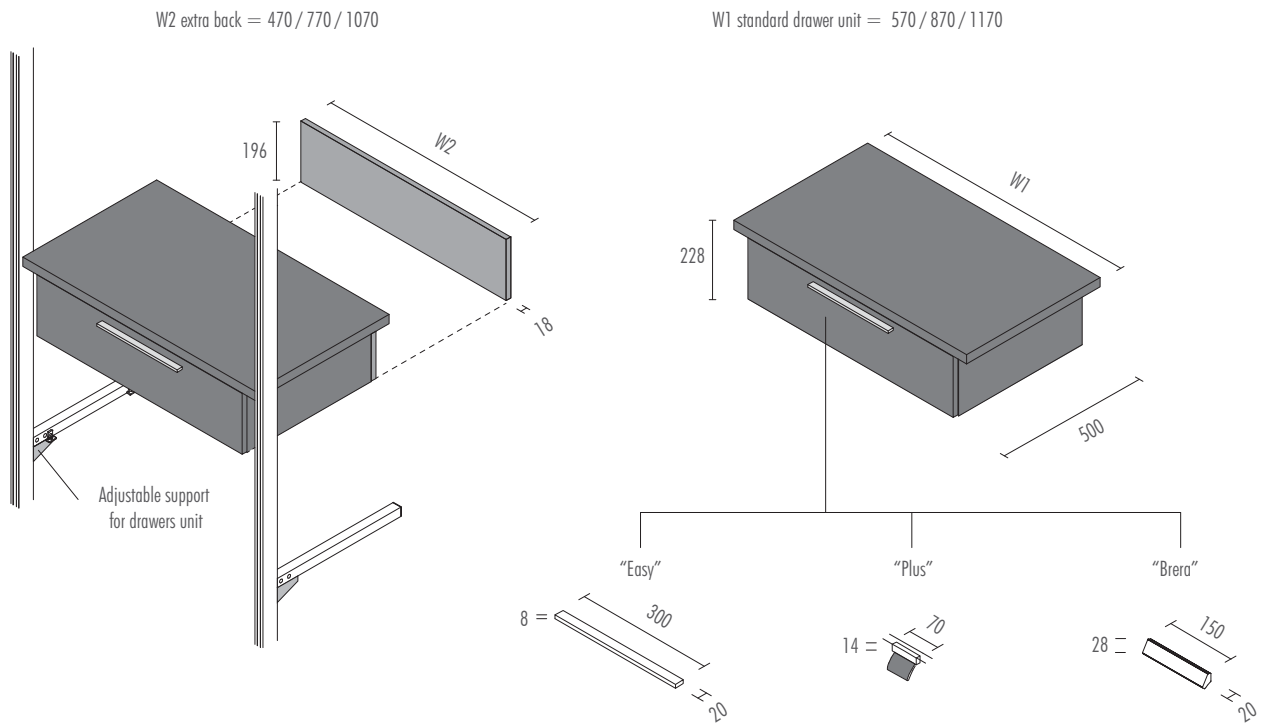

2 DRAWER UNIT

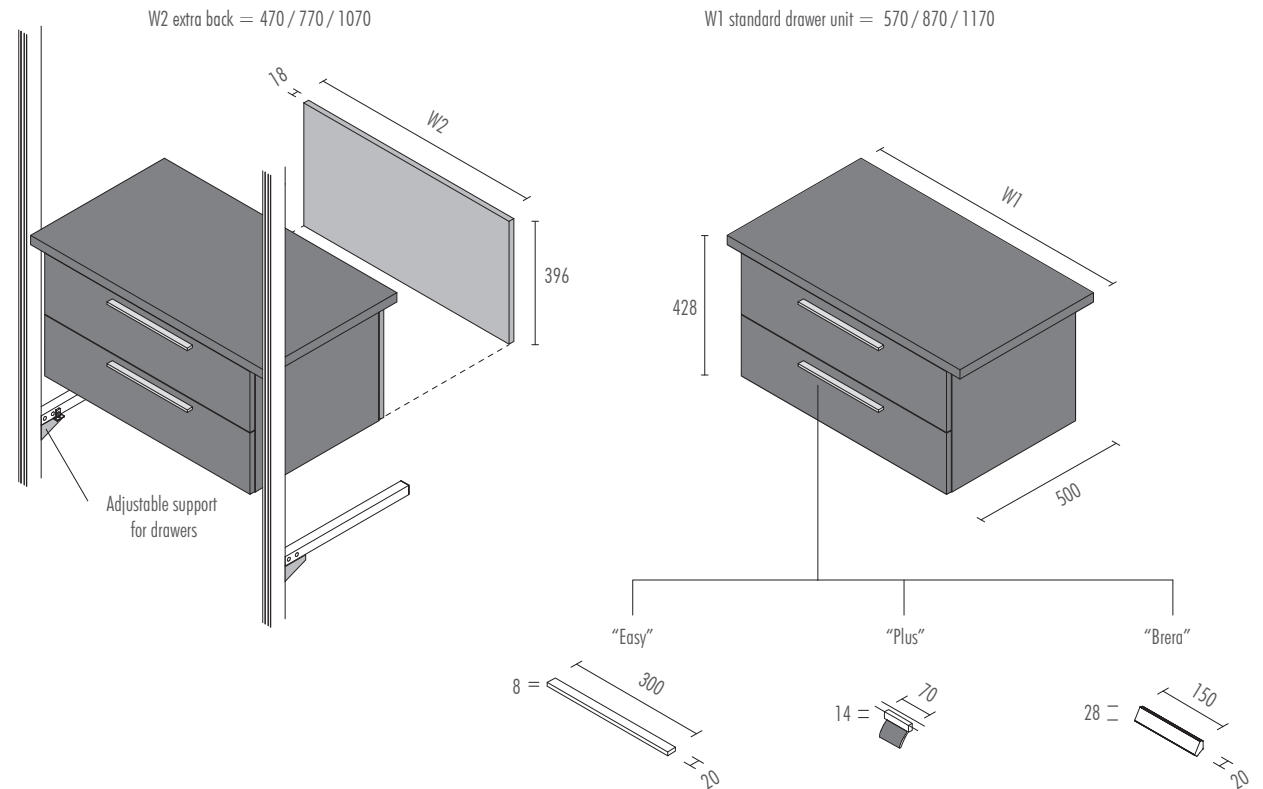

3 DRAWER UNIT

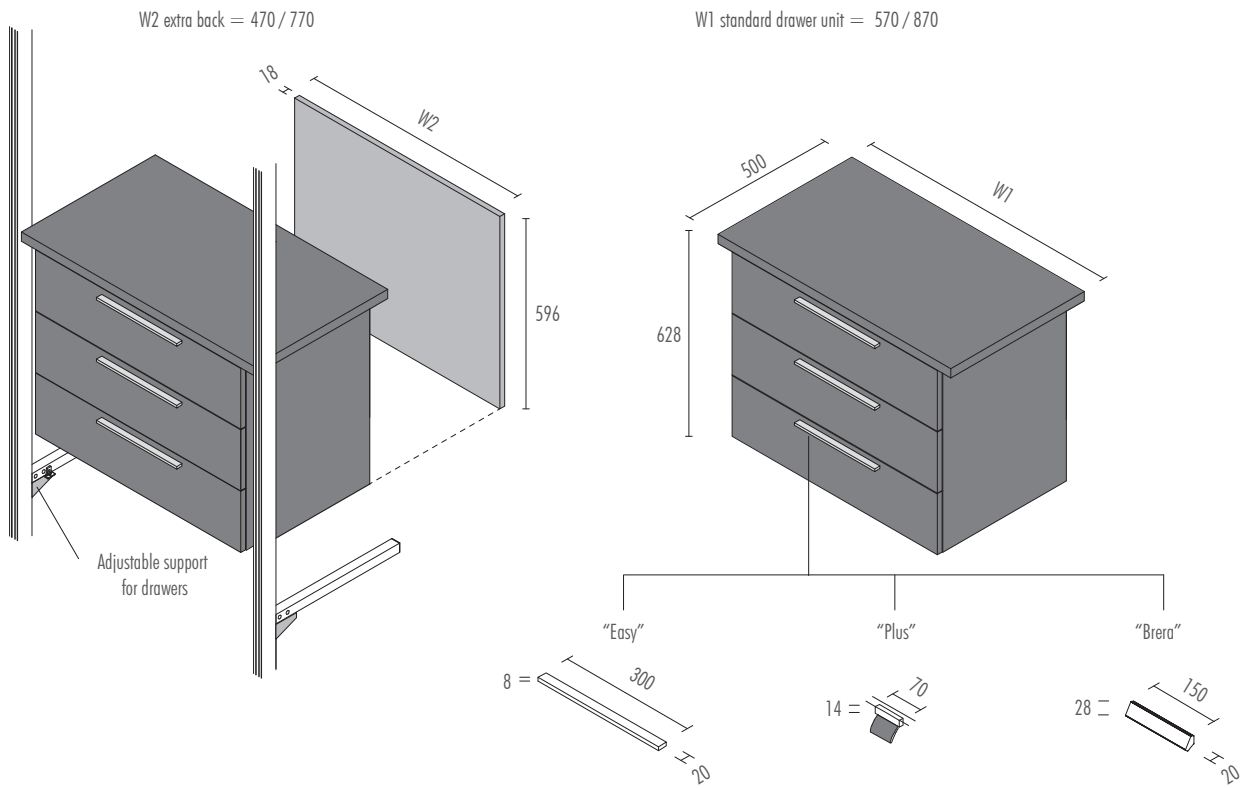

EQUIPMENT

DRAWERS SHIRT-HOLDER

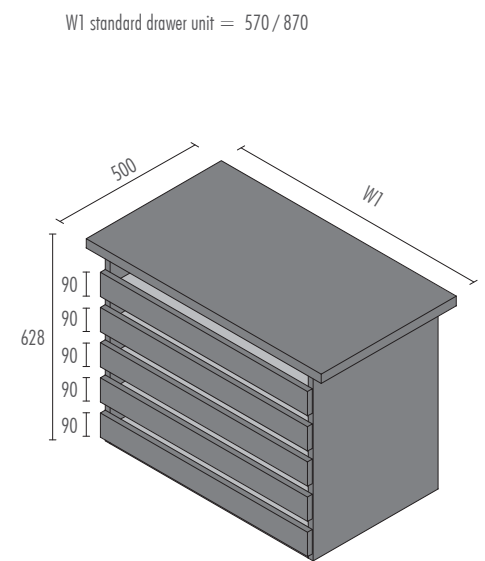
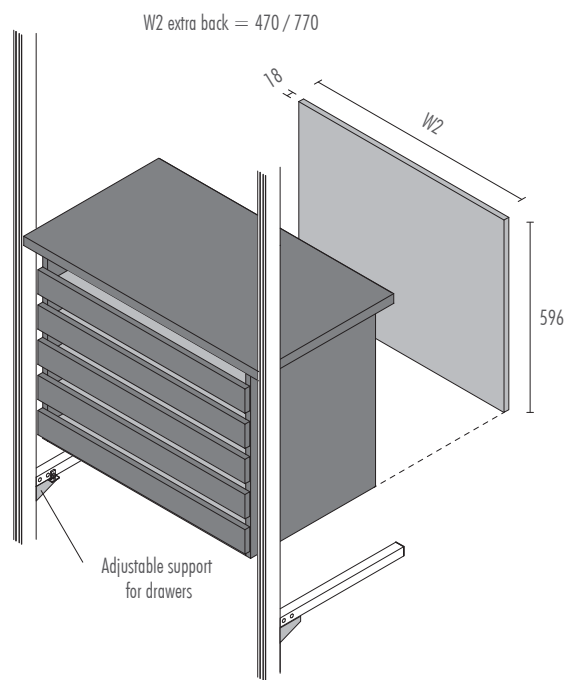
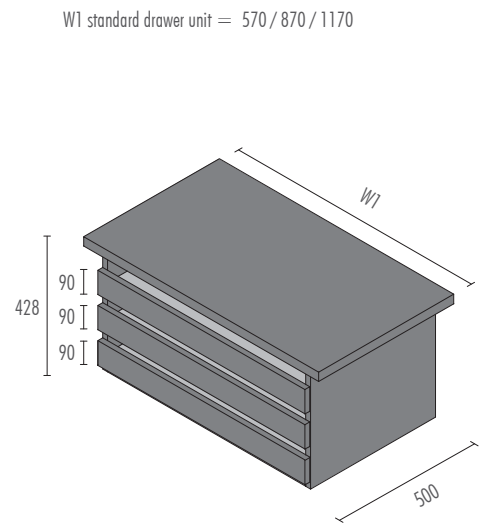
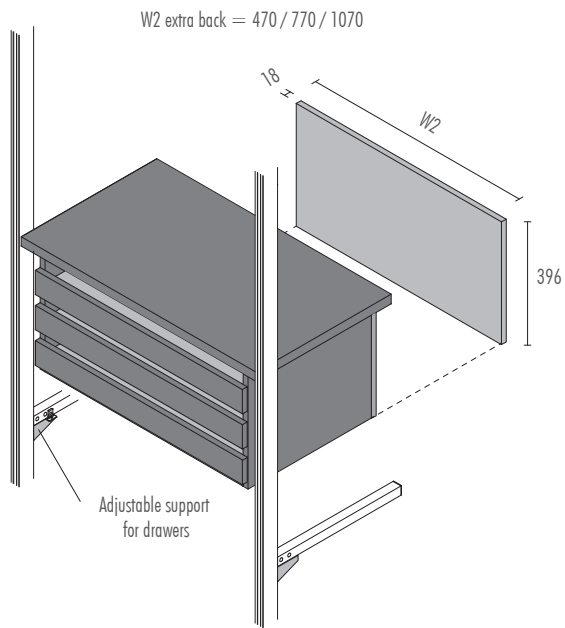

OPEN BASE UNIT

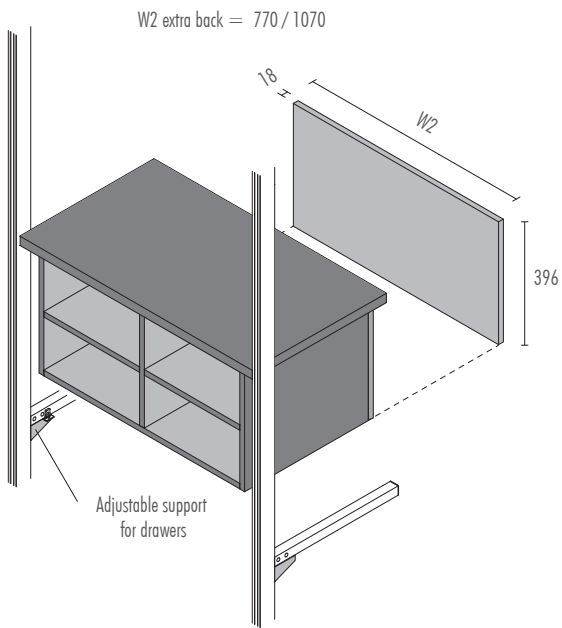

Open base unit for W 900 module

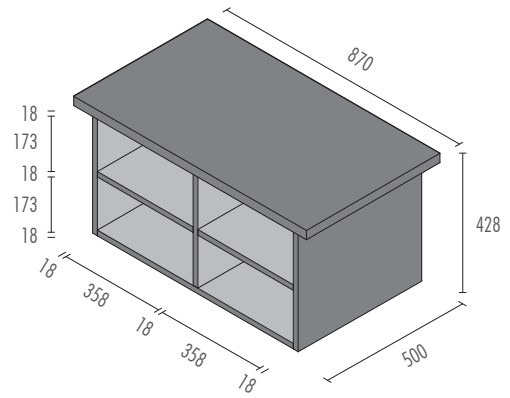

Open base unit for W 1200 module

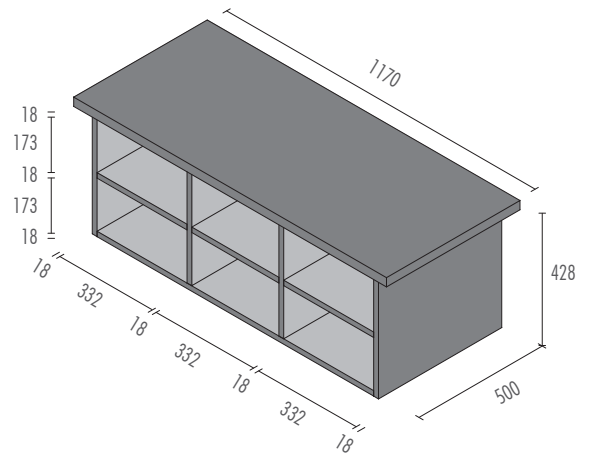

EQUIPMENT

DRAWERS UNIT ON WHEELS

W1 standard drawer unit = 770 / 1070

W2 extra back = 770 / 1070

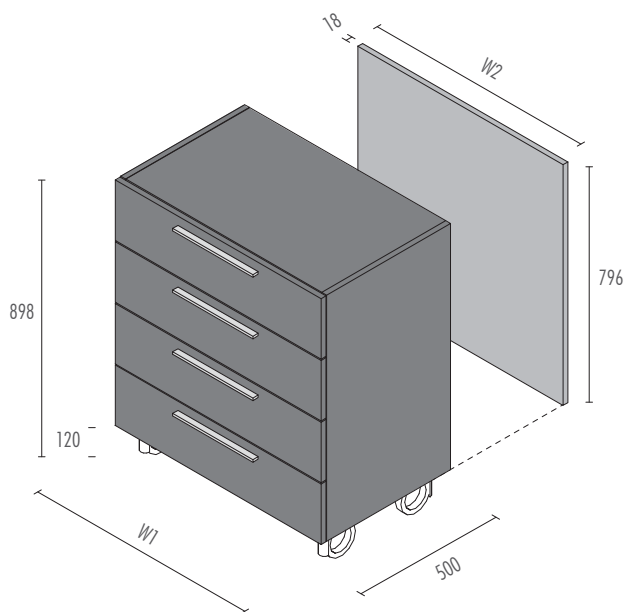
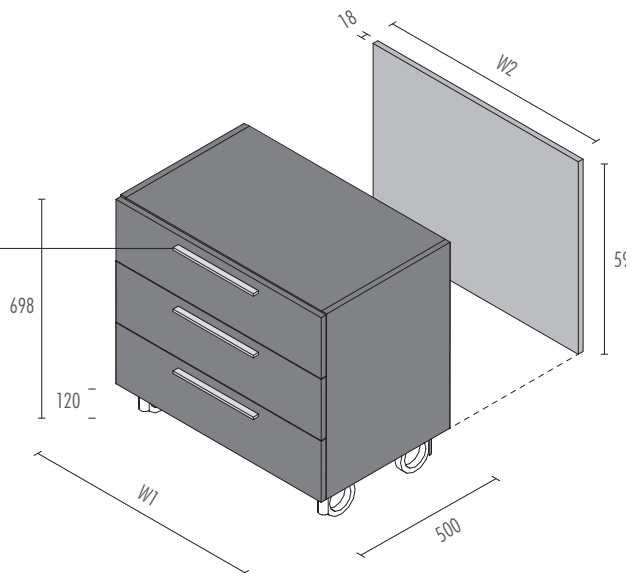
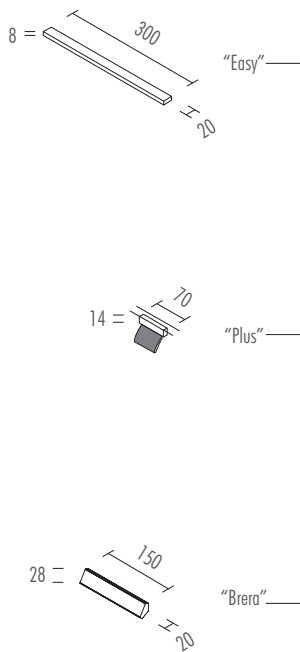
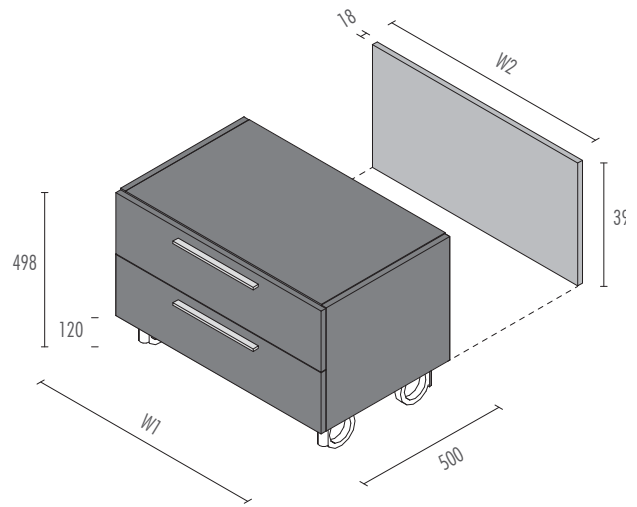

WALK-IN WARDROBE SOLO FREESTANDING

COMPONENTS' LIST FOR FREESTANDING SOLUTION

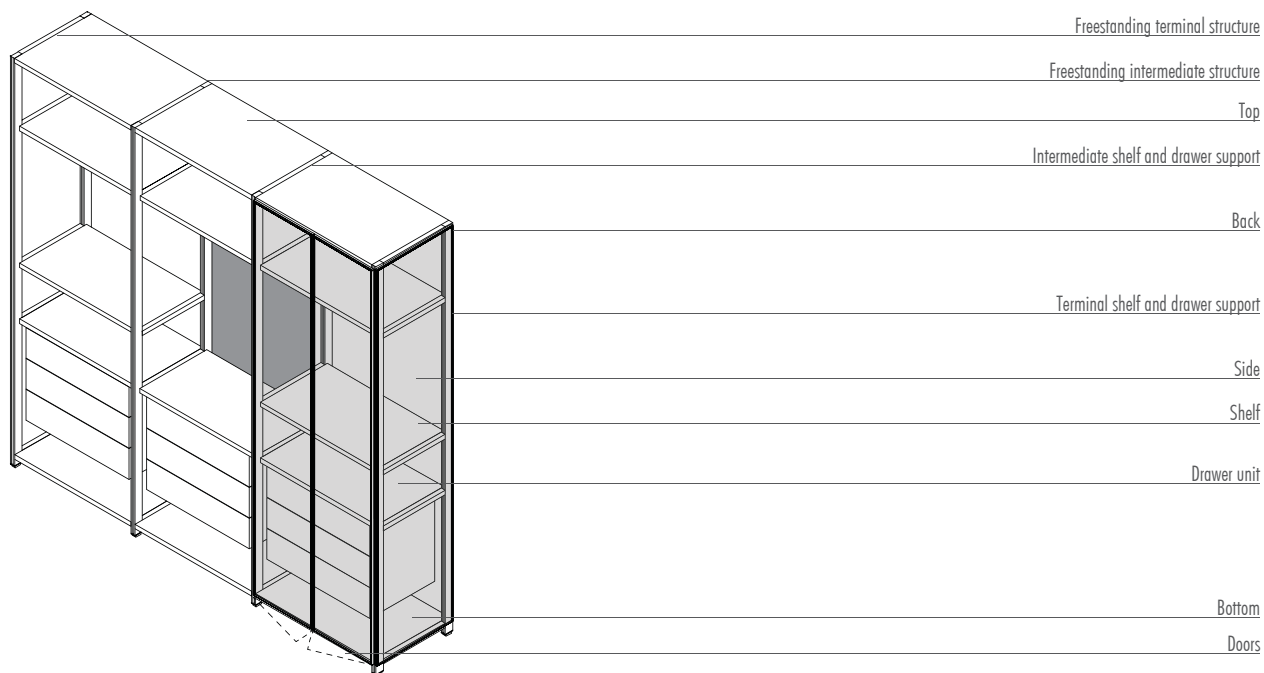

VERTICAL SECTION OF FREESTANDING SOLUTION

Shelf and drawers, except for the top and the bottom, can be freely arranged.

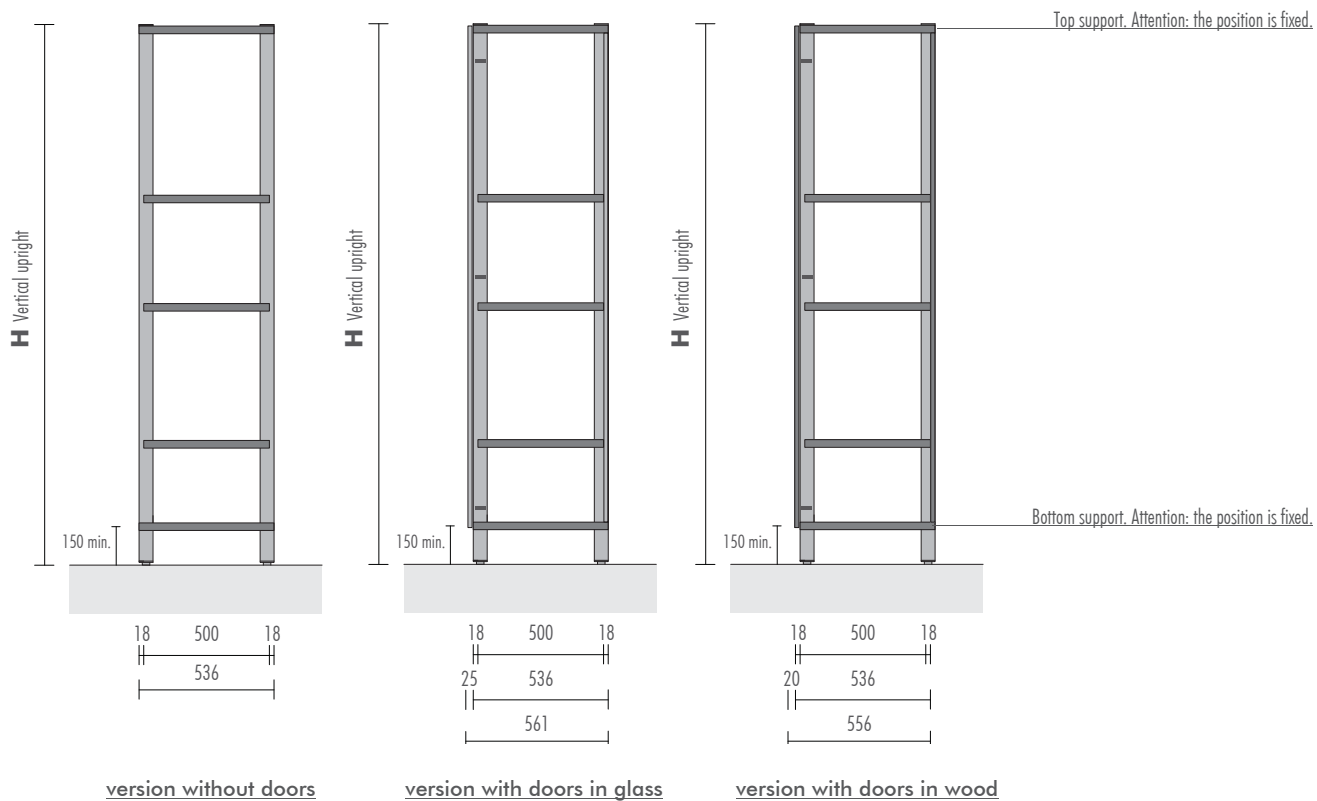

BACK

Attention: every freestanding SOLO composition needs at least one back.

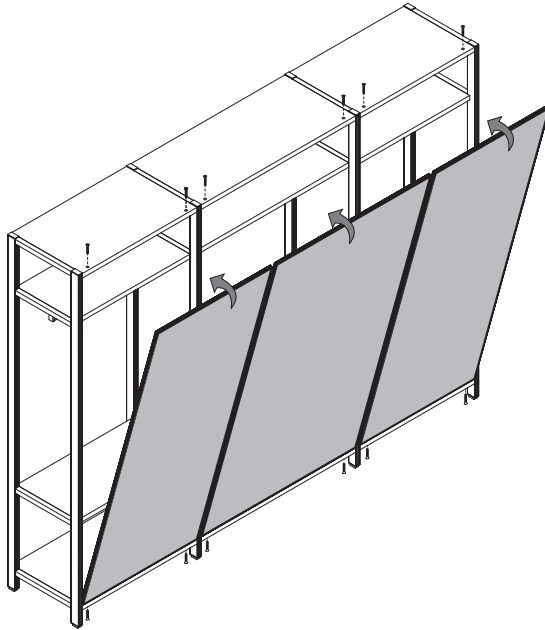

SIDE CLOSING PANEL

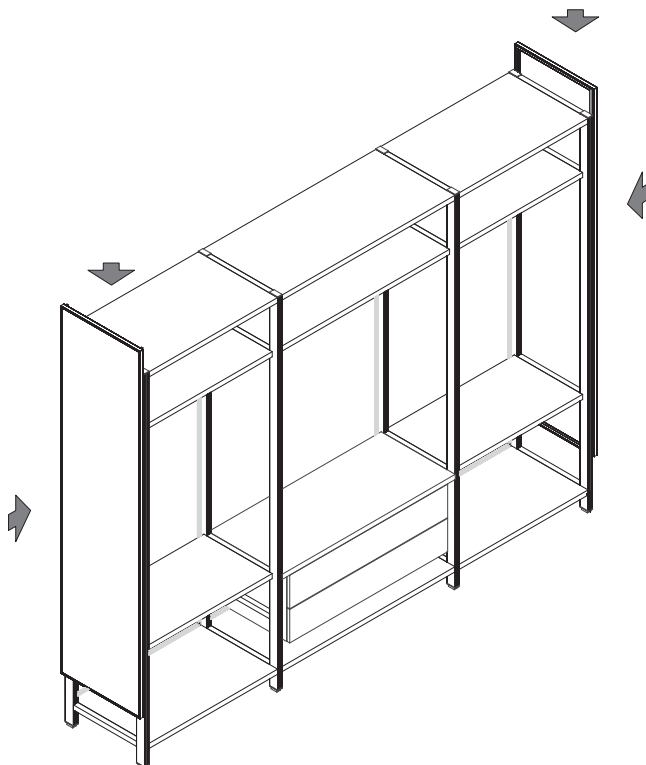

EQUIPMENT

TOP AND BOTTOM

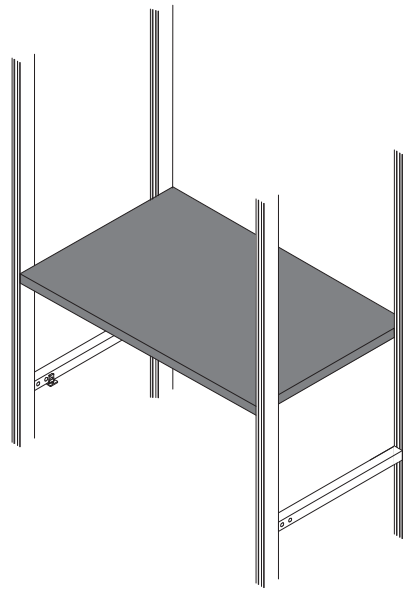

W STANDARD = 420 / 570 / 870 / 1170

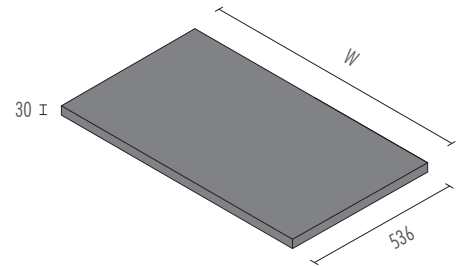

SHELF

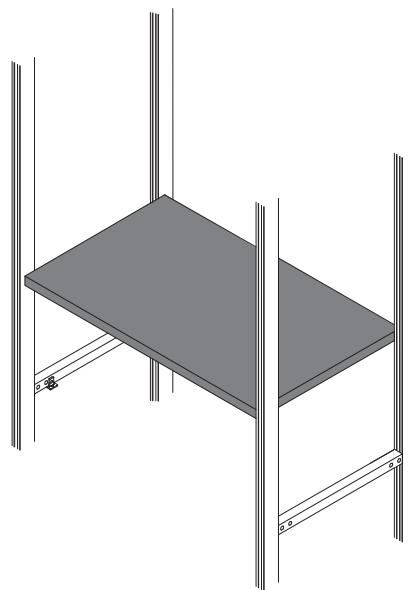

W STANDARD = 420 / 570 / 870 / 1170

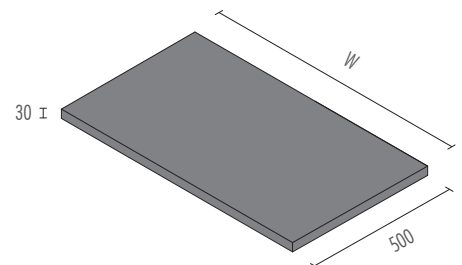

SHELF WITH CLOTHES HANGER

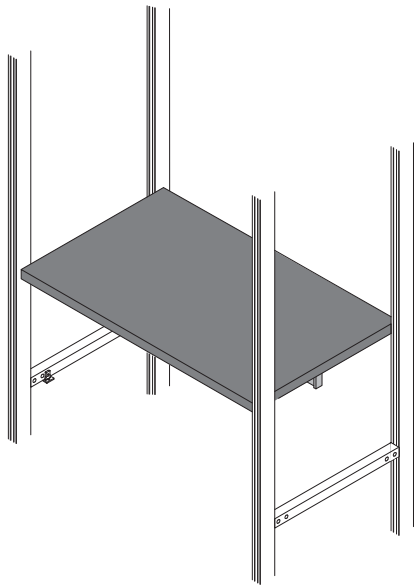

W STANDARD = 420 / 570 / 870 / 1170

W1 = W standard - 60 mm

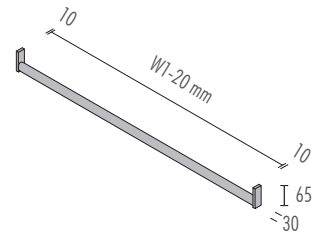
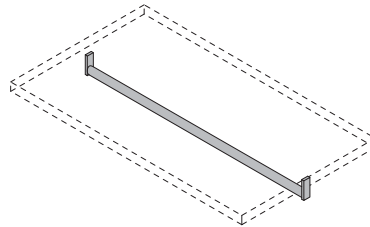
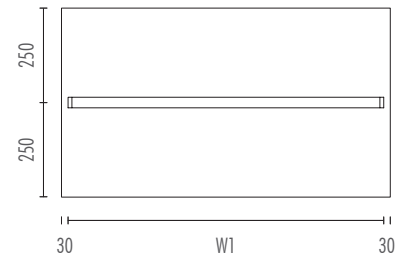
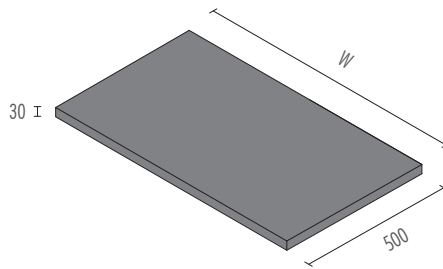

SHELF FOR SHOES

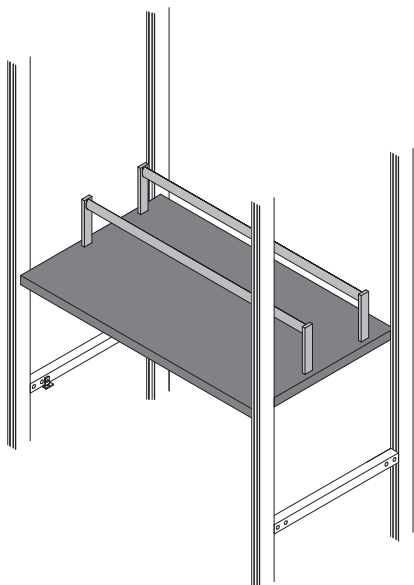

W STANDARD = 870 / 1170

W1 = W standard - 60 mm

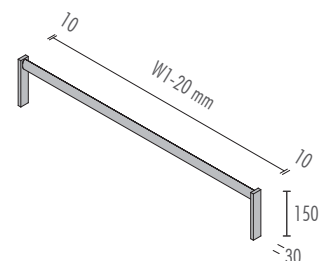
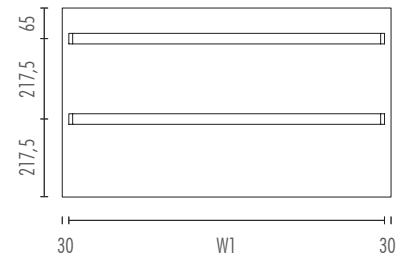
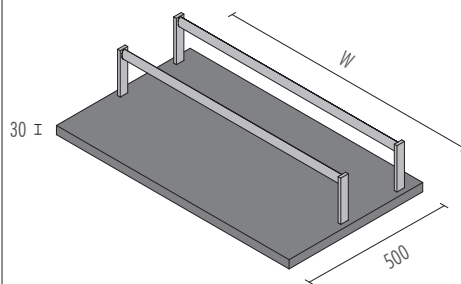

EQUIPMENT

TROUSERS HANGER

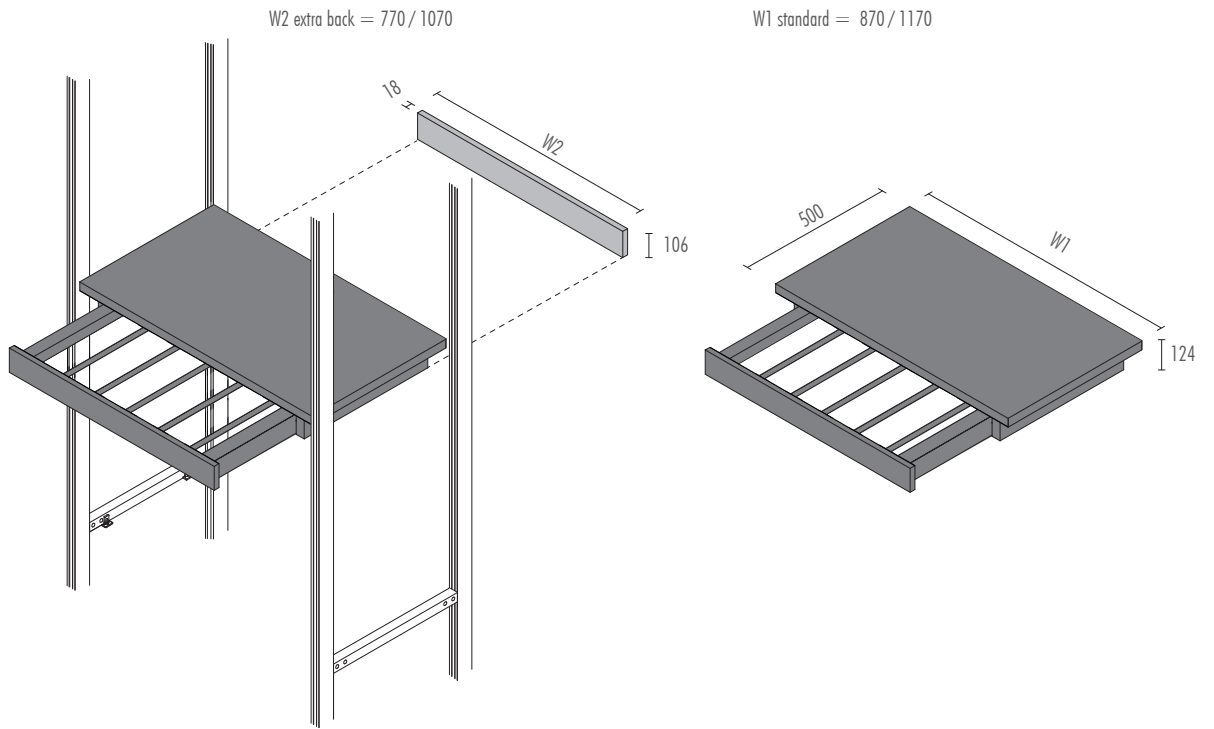

1 DRAWER UNIT

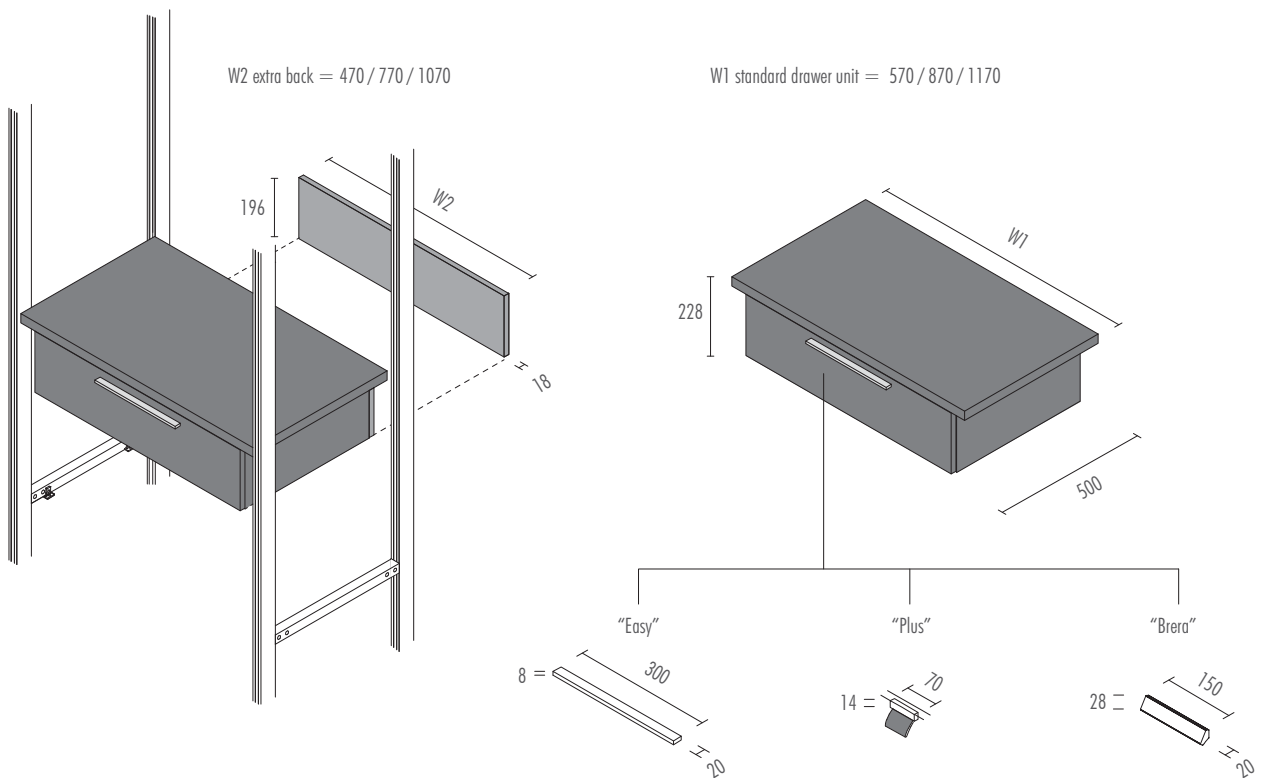

2 DRAWER UNIT

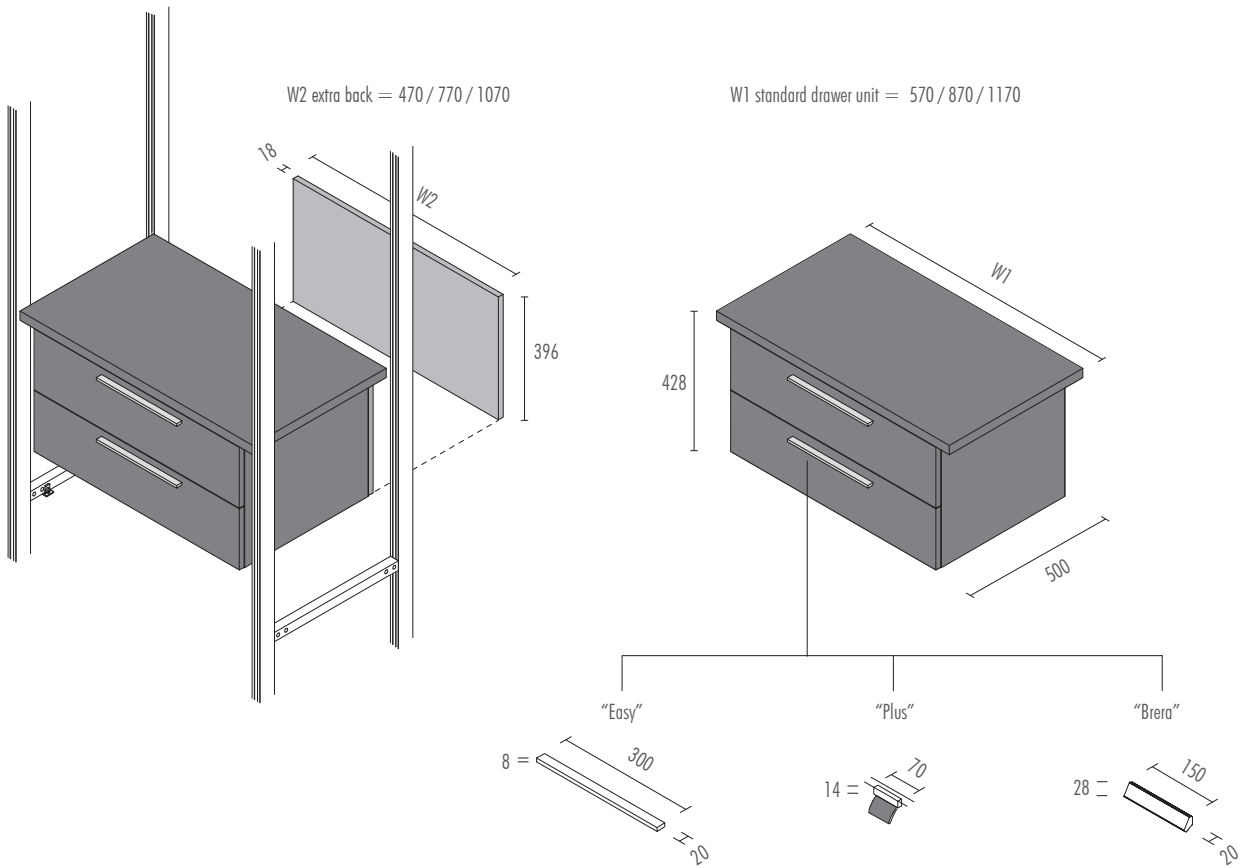

3 DRAWER UNIT

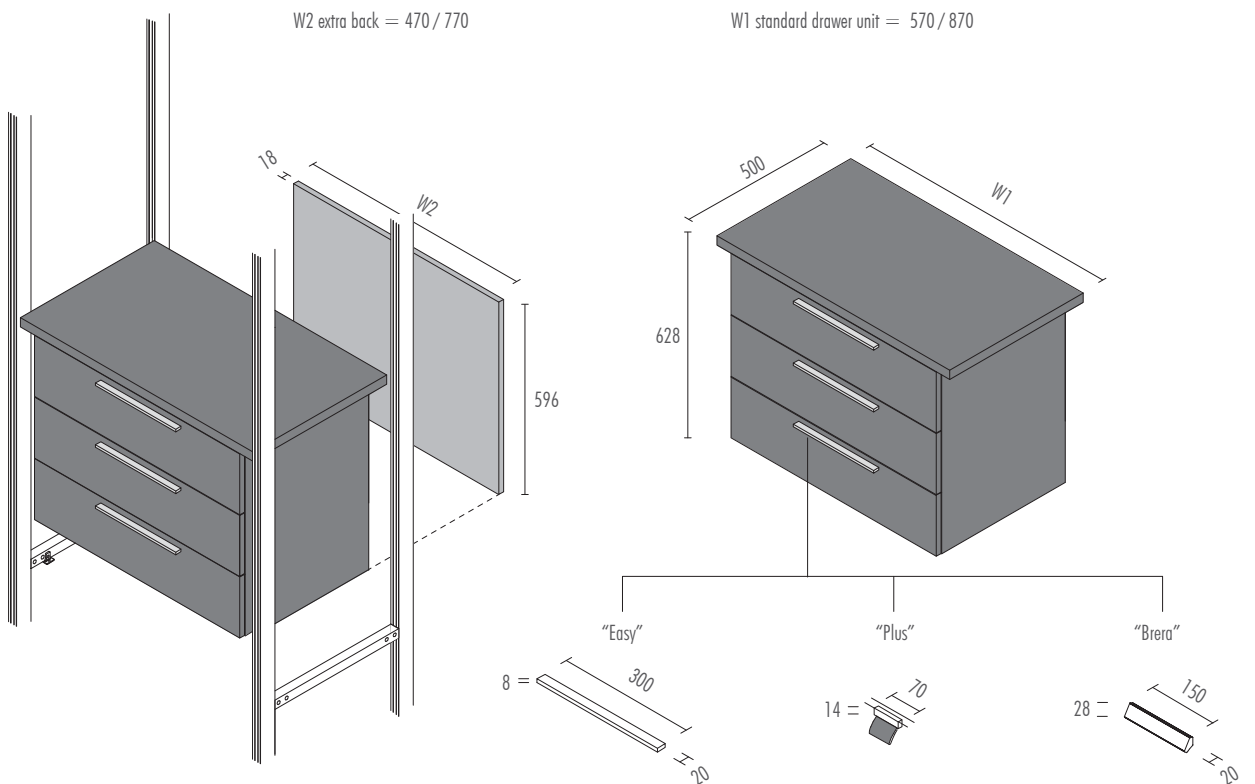

EQUIPMENT

DRAWERS SHIRT-HOLDER

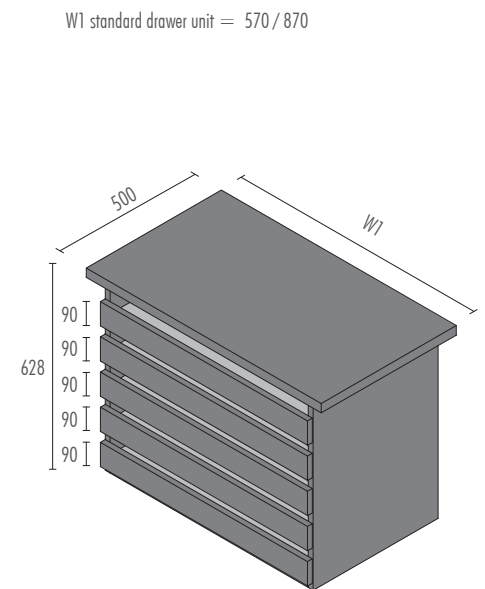
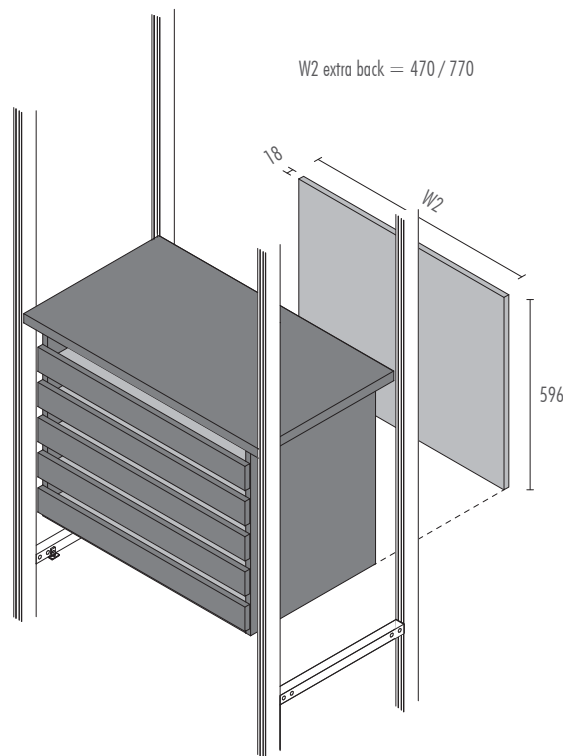
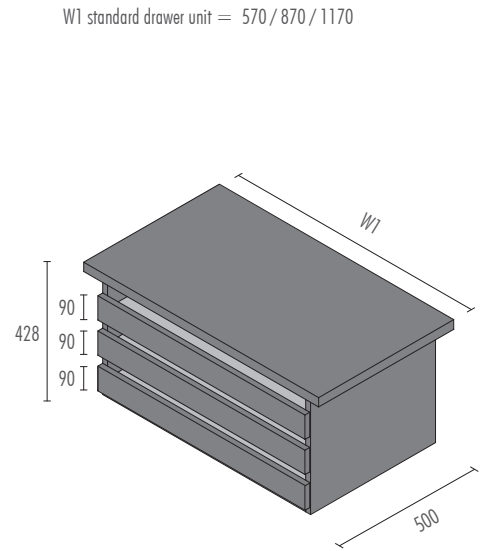
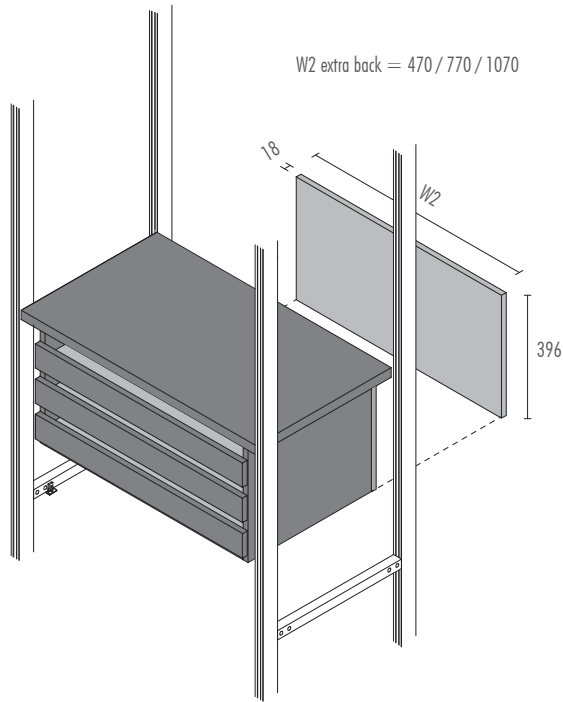

OPEN BASE UNIT

